

NEU6210U



**ENGINEERING CODE**  
862PA51



**REFRIGERANT**  
R-290



**POWER SUPPLY**  
220-240 V 50 Hz



**APPLICATION**  
MBP



**MOTOR TYPE**  
CSIR



**STANDARD**  
ASHRAE



**COOLING CAPACITY**  
718 W



**EFFICIENCY**  
1.83 W/W



DATA

GENERAL DATA

Model	NEU6210U
Type	Hermetic Reciprocating
Technology	ON/OFF
Compressor Application	MBP
Expansion Device	Capillary Tube or Expansion Valve
Compressor Cooling	Fan/220
HP	1/3
Starting Torque	HST
Plant	SLOVAKIA

ELECTRICAL DATA

Start Winding Resistance	14.1 Ω at 25°C
Run Winding Resistance	5.97 Ω at 25°C
Locked Rotor Amperage (LRA) 50Hz	18 A

## MECHANICAL DATA

Displacement	8.77 cm <sup>3</sup>
Oil Charge	350 ml
Oil Type	AB
Oil Viscosity	ISO32
Weight	10.3 Kg

## ELECTRICAL COMPONENTS

Start Capacitor	53-64 µf/330 V
CSR CSIR BOX	No
Starting Device Type	RELAY
Starting Device Description	MTRP-0030*
Overload Protection	MST26ALK-3259

## PERFORMANCE

### TESTED CONDITIONS

Tested Refrigerant	R-290
Tested Application	MBP
Tested Standard	ASHRAE
Tested Cooling	Fan
Tested Voltage	220 V
Refrigerant Temperature	Dew

### RATED POINTS

Condensing Temperature °C	Evaporating Temperature °C	Cooling Capacity W	Efficiency W/W	Power Consumption W	Current A	Gas Flow Rate kg/h
54.4	-6.7	718	1.83	392	3.18	8.22

Test Condition: Subcooling 8.3 K, Return Gas 35 °C. Data generated in accordance to EN 12900:2013 polynomial equation and tolerance guidelines.

### PERFORMANCE CURVE

Condensing Temperature 35°C

Evaporating Temperature °C	Cooling Capacity W	Efficiency W/W	Power Consumption W	Current A	Gas Flow Rate kg/h
-20	541	1.85	293	2.99	5.21
-15	675	2.17	311	3.03	6.52
-10	830	2.52	329	3.06	8.06
-5	1010	2.92	345	3.08	9.85
0	1215	3.42	355	3.11	11.91
5	1447	4.06	356	3.13	14.28
10	1708	4.96	344	3.14	16.99

Test Condition: Subcooling 8.3 K, Return Gas 35 °C. Data generated in accordance to EN 12900:2013 polynomial equation and tolerance guidelines.

## PERFORMANCE CURVE

Condensing Temperature 45°C

Evaporating Temperature °C	Cooling Capacity W	Efficiency W/W	Power Consumption W	Current A	Gas Flow Rate kg/h
-20	463	1.46	317	2.99	4.82
-15	582	1.73	336	3.04	6.09
-10	722	2.01	359	3.09	7.58
-5	885	2.31	383	3.14	9.33
0	1071	2.65	405	3.18	11.37
5	1284	3.05	421	3.22	13.72
10	1524	3.57	427	3.26	16.42

Test Condition: Subcooling 8.3 K, Return Gas 35 °C. Data generated in accordance to EN 12900:2013 polynomial equation and tolerance guidelines.

## PERFORMANCE CURVE

Condensing Temperature 55°C

Evaporating Temperature °C	Cooling Capacity W	Efficiency W/W	Power Consumption W	Current A	Gas Flow Rate kg/h
-10	619	1.66	374	3.15	7.10
-5	763	1.89	403	3.21	8.79
0	929	2.15	432	3.27	10.78
5	1120	2.44	459	3.33	13.10
10	1338	2.79	480	3.38	15.77

Test Condition: Subcooling 8.3 K, Return Gas 35 °C. Data generated in accordance to EN 12900:2013 polynomial equation and tolerance guidelines.

## ENVELOPE

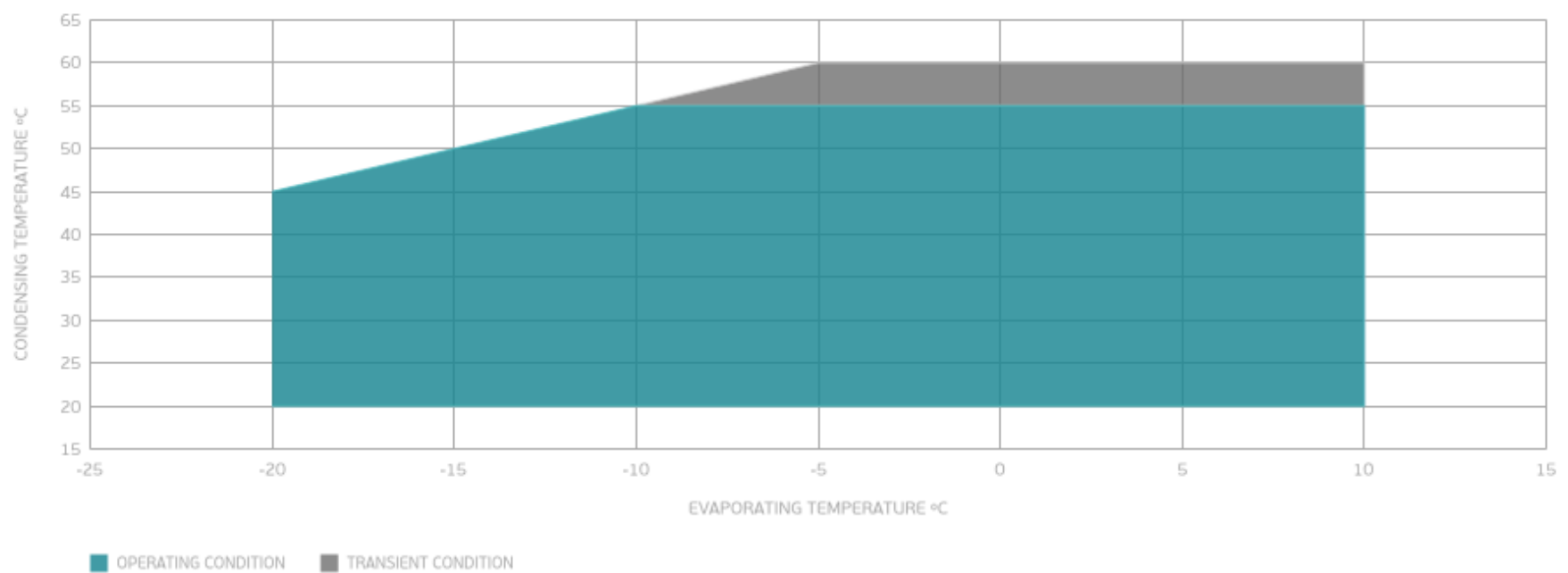

## External

### EXTERNAL CHARACTERISTICS

Base Plate		SMALL	
Tray Holder		NO	
<b>Connector</b>	<b>Internal Diameter</b>	<b>Shape</b>	<b>Material</b>
Suction	8.1 mm	SLANTED 42°	COPPER
Discharge	6.1 mm	STRAIGHT	COPPER

**EXTERNAL DIMENSIONS**

**SHELL**

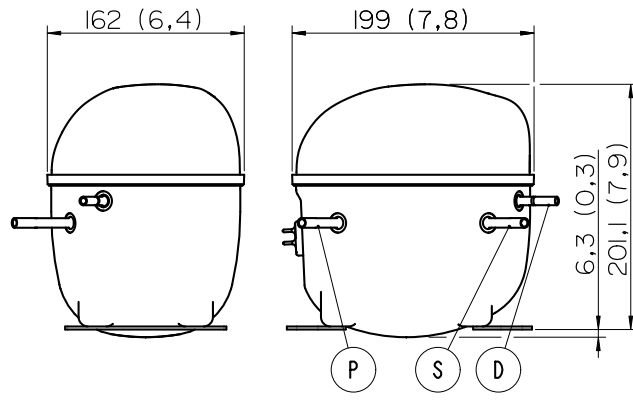

**BASE**



**FENCE**

