

Controllers for cold rooms



XER: the new family of controllers for cold room management



The new XER family of controllers is the ideal solution for the management of all kinds of cold room application, regardless of performances or dimensions, from small shops to a restaurant, from supermarket to a large storage center. It is ready to answer most needs of the retail and food service world.

This series ensures an easy installation mode and an intuitive configuration meeting all installers and service staff needs.

Energy efficiency is ensured by the automation of lights and/or evaporator fans switching them ON or OFF depending on personnel presence (X-MOD sensor), while the homogeneous temperature control inside the cold room improve food storage.

Besides the basic configuration, it is possible to choose models with circuit breaker and residual current circuit breaker.

1. Complete cold room management

Because of its high-performance hardware and enhanced functions, XER is ready to answer most needs of the cold rooms currently on the market.

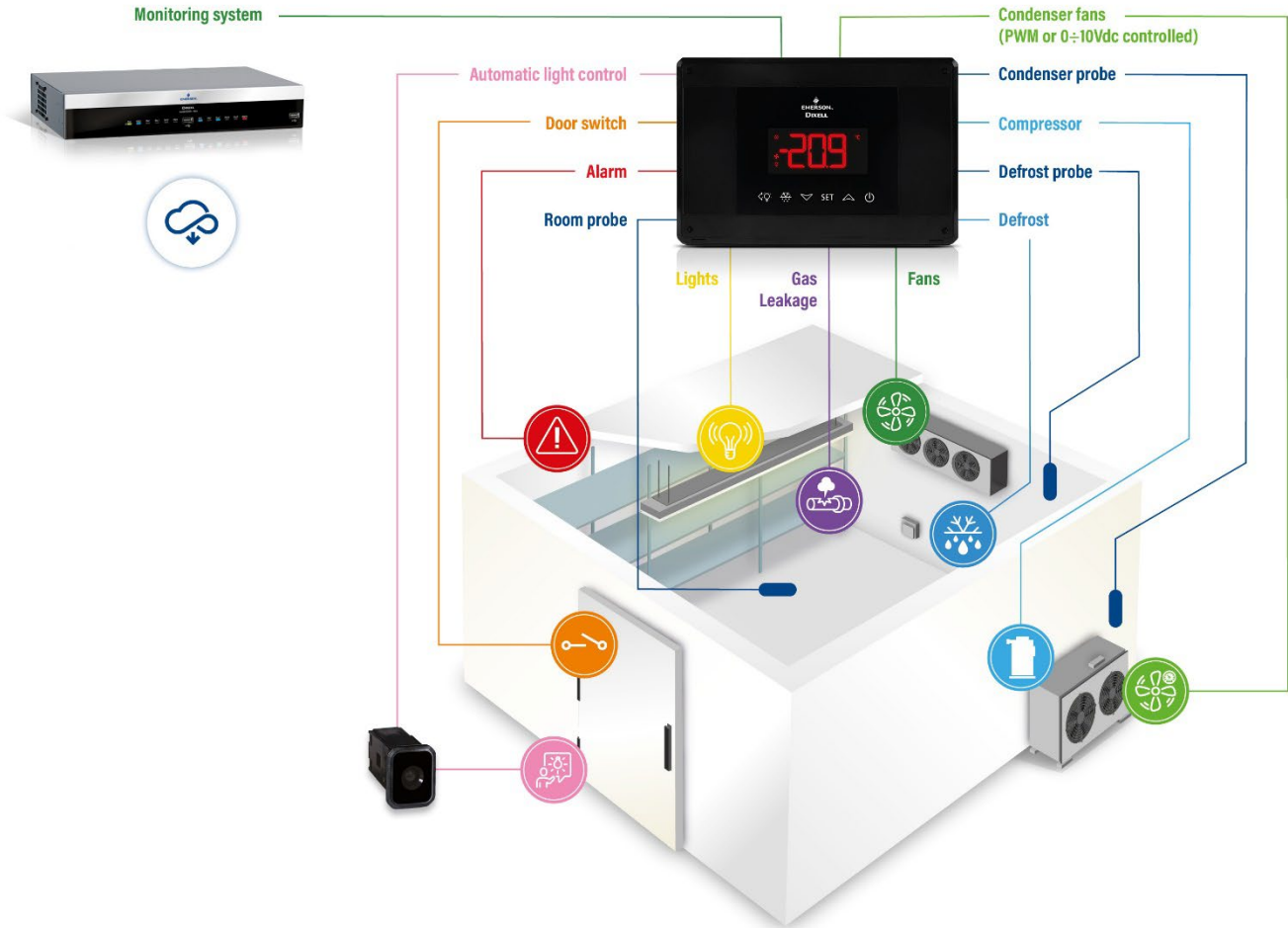

2. General features

2.1 Clear indication of malfunctioning or regulation failures



With to the innovative alarm frame, any alarm condition or regulation failure can be signaled in a more effective way, making it clearly visible from longer distances.



2.2 User friendly



The simplified navigation makes controller easier to use. A quick parameter search method speeds up the commissioning phases and maintenance operations through a driven label selection in these 3 simple steps.



The useful frontal output allows a quick, easy and safe firmware update by using the Wizmate software, without opening the enclosure. Furthermore, the output allows to connect the Hot Key for the parameter update.

Big & flat buttons can be easily pressed also with gloves.

2.3 Environmentally friendly



Reduced power consumption, pollution and gas emissions through optimized regulation and load controls (fans, lights, heaters, and more) via selectable analogue outputs (PWM, 0÷10Vdc or 4÷20mA).

2.4 Modular enclosure



The enclosure is modular and easy to expand. Moreover electromechanical components (for example a circuit breaker) can be installed inside the enclosure.

2.5 Safeties



The "Pump Down" logic helps to reduce liquid return conditions, dangerous for the compressor, when long piping connects condensing unit and evaporator.

Moreover, XER controllers can manage safety checks depending on personnel presence inside the cold room, with the possibility to disable the regulation during warning conditions.

2.6 Homogeneous temperature control



Food storage inside the cold room can be improved measuring the average value of multiple probes for the temperature regulation. This special function is highly valued for large cold rooms where the temperature results can be different and not homogeneous, affecting the quality of the product.

2.7 Gas leak detection



Controllers, through an external gas sensor, can promptly signal possible refrigerant losses, maintaining safe conditions inside the cold room and avoiding machine stops due to gas leaks in the refrigeration circuit. A tempestive intervention reduces waste of gas and products inside the room and prevents its deterioration.

2.8 Automatic light control



The attention to the usage and control of lights and evaporator fans is synonyms of energy saving and safety: the usage of the X-MOD motion sensor automates lights and/or evaporator fan management. Interior and/or aisle lights can be switched on if human presence is detected near or inside the cold room. Evaporator fans can be stopped in case of human presence is detected inside the cold room to increase the safety of the application.



2.9 Double parameter map



Two parameter maps are available on XER; the user can select the most suitable for its application and quickly set parameters. The possibility to restore the factory default settings, a very useful operation in case of mistakes during the programming, allows automatic re-configuration of the controller to have it operating again for a subsequent and easier update.

2.10 Real time clock with replaceable lithium battery



Controllers are equipped with a lithium battery, which ensures data-saving even during long blackout periods. The system promptly advises when the charge of the battery goes below the set threshold, allowing its preventive replacement and ensuring saved data is secure.

3. Hardware features

3.1 Features

	Circuit breaker		Residual current Circuit breaker			
	XER140P	XER160P	XER241P	XER261P	XER242P	XER262P
Display	3 digits with decimal point, icons and alarm frame	3 digits with decimal point, icons and alarm frame	3 digits with decimal point, icons and alarm frame	3 digits with decimal point, icons and alarm frame	3 digits with decimal point, icons and alarm frame	3 digits with decimal point, icons and alarm frame
Power supply	230Vac	230Vac	230Vac	230Vac	230Vac	230Vac
Probe inputs	2 x NTC/PT1000 configurable	4 x NTC/PT1000 configurable	2 x NTC/PT1000 configurable	4 x NTC/PT1000 configurable	2 x NTC/PT1000 configurable	4 x NTC/PT1000 configurable
Digital inputs	2 x configurabili	2 x configurabili	2 x configurabili	2 x configurabili	2 x configurabili	2 x configurabili
Relay outputs	2x20A SPST + 1x16A SPST + 1x8A SPDT all configurable	2x20A SPST + 2x16A SPST + 1x8A SPST+ 1x8A SPDT all configurable	2x20A SPST + 1x16A SPST + 1x8A SPDT all configurable	2x20A SPST + 2x16A SPST + 1x8A SPST+ 1x8A SPDT all configurable	2x20A SPST + 1x16A SPST + 1x8A SPDT all configurable	2x20A SPST + 2x16A SPST + 1x8A SPST+ 1x8A SPDT all configurable
Hot Key port	internal	intemal	internal or external	intemal or external	intemal or external	intemal or external
0÷10Vdc output	optional	optional	optional	optional	optional	optional
PWM output	optional	optional	optional	optional	optional	optional
Serial outputs	TTL + RS485 optional	TTL + RS485 optional	TTL + RS485 optional	TTL + RS485 optional	TTL + RS485 optional	TTL + RS485 optional
Real time clock	optional	optional	optional	optional	optional	optional

3.2 Connections

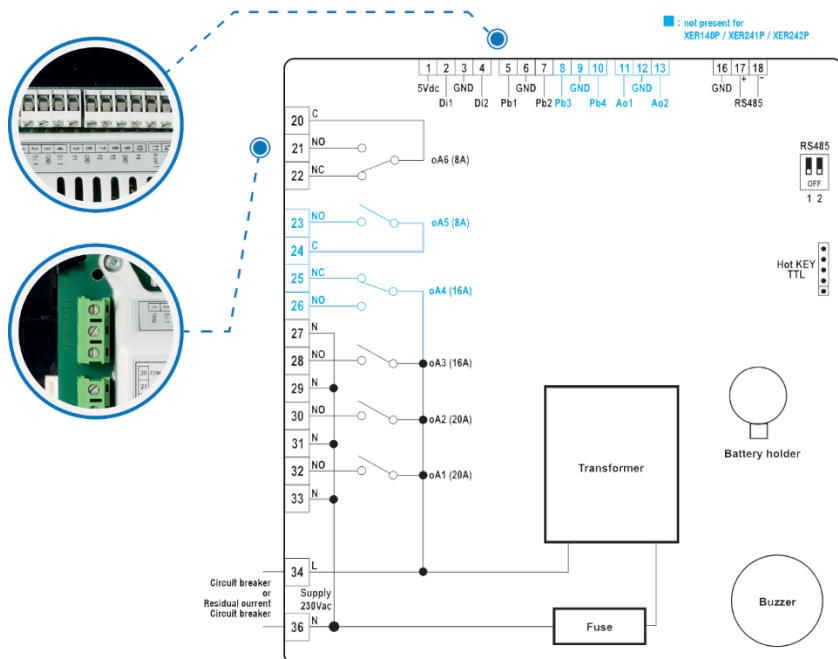

Suitable for the most applications in the cold room market: relay outputs can be configured with 4 direct loads and 2 additional relays.



Easier installation with inclined terminals.



Simplified and increased connection speed with the rising clamp terminals that can accept cross-section cables up to 4mm².

3.3 Mounting

The XER family features quick and easy DIN Rail or wall mounting.

The cable glands ensure an IP protection degree of the product and the hinges, which keep the electronic part mounted with the rest of the box, allow a safe and easy wiring.



DIN Rail mounting

Allows an efficient alignment of multiple controllers in case of applications with several cold rooms.

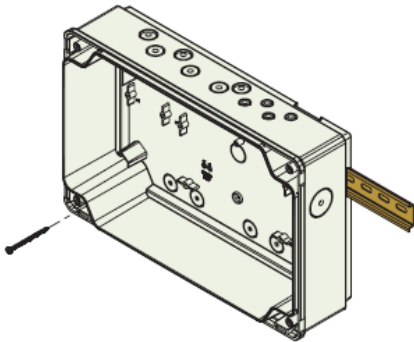

Wall mounting

Quick and safe wall mounting through 4 screws with pre-formed posts separated by gasket from the inner part.

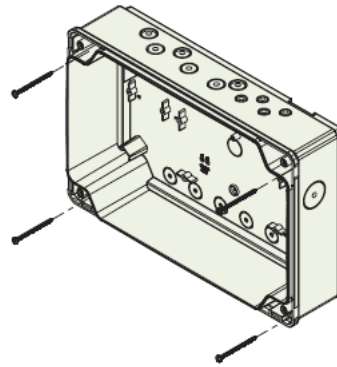

3.4 Dimensions

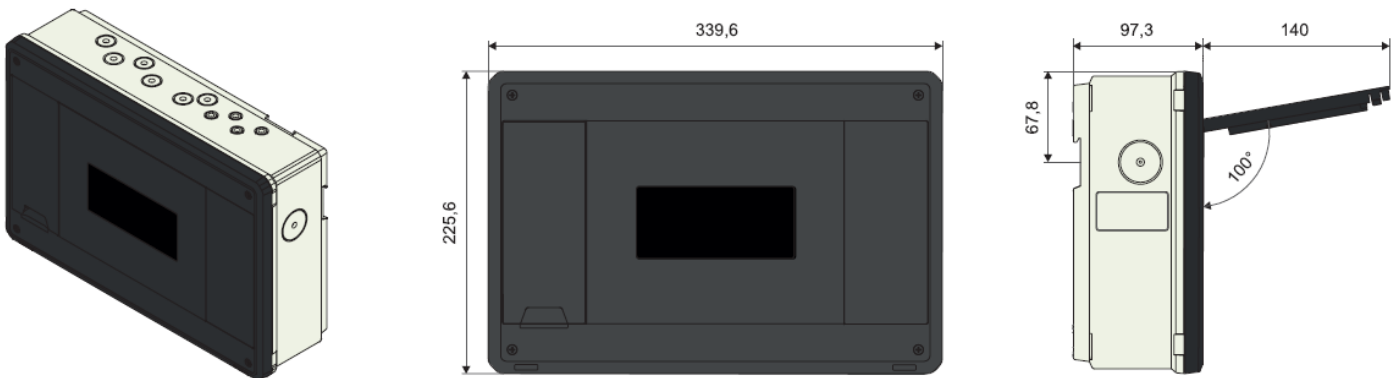

4. Main accessories

	<p>X-MOD 5V Motion detection sensor that allows to detect the proximity of customers or service staff.</p>
	<p>XJ485CX Serial interface converts the TTL output into an RS485.</p>
	<p>HOT KEY 64K Key for a quick and easy programming. It is used to upload (from the device memory to the HOT-KEY) and to download (from the HOT-KEY to the device memory) the parameter map.</p>
	<p>XJ485USB-KIT Converter from USB to RS485 (2 wires) which allows to monitor one or more controllers networked to a computer. It is equipped with a galvanic isolation (max isolation voltage 2.5kV on data channels).</p>
	<p>WIZMATE Programming tool for controllers and Hot Key.</p>
	<p>KIT CABLE GLANDS Cable gland kit (4xPG7 + 6xPG11).</p>
	<p>HOT KEY EXT Cable and connector for external Hot Key.</p>

5. How to order

XER140P – 5 N C 0 0 F

XER160P – 5 N C 0 4 F

XER24_P – 5 N C D 0 F

XER26_P – 5 N C D 4 F

C			D		F			
	Measurement unit	RS485		External Hot Key port		RTC	PWM	Analog output
0	°C	No	0	No	0	No	No	No
1	°C	Yes	1	Yes	3	No	Yes	Yes
A	°F	No			4	Yes	No	No
B	°F	Yes			7	Yes	Yes	Yes

6. Pricing

Please contact our Sales dpt. for product pricing and further information.

7. Availability and orders

XER controllers are available from March 2023 with standard delivery time. Please contact our Sales dpt. for further information.